

**CAM
EQUIPMENT**

TELEPHONE: 01761 434226
 FAX No.: 01761 435541
 WEB SITE: WWW.CAMequipment.co.uk
 E-Mail: Enquiries@CAMequipment.co.uk

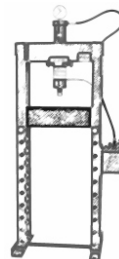

FROME HILL, RADSTOCK, Nr BATH, BA3 3PY

MANUFACTURES OF QUALITY GARAGE & WORKSHOP EQUIPMENT SINCE 1972

WORKSHOP CRANES WITH REMOVABLE LEGS

508 KG, 750 KG & 1000 KG CAPACITY

ALL CRANES ARE FITTED WITH A DOUBLE ACTING PUMP AND SEPARATE HYDRAULIC RAM FOR LONGER SEAL LIFE. NOT A HYDRAULIC BOTTLE/COMBINATION UNIT JACK AS FITTED TO MOST HYDRAULIC WORKSHOP CRANES.



ALL MODELS HAVE REMOVABLE LEGS FOR EASE OF TRANSPORTATION.

- **Space Saving** Fold-away Cranes available in three models for use in vehicle and industrial workshops. Cranes pack into a **Compact Free Standing** unit to save space when not in use.
- **All** models fitted with a **Safety Relief Valve** to prevent overloading.
- **Top Quality Hydraulics** fitted with **Chrome Plated Piston Rod on Pump and Ram.**
- **12 Months Guarantee.**
- **Robust Construction.**
- Fitted with **Hard Wearing** Nylon front wheels and rear castor wheels for easy movement of the crane when operational or folded.
- Manufactured from hollow steel box section for combined **Strength and Lightness.**
- **Tested to 25% Overload.**
- **Individual Test Certificate/Letter of Conformity** supplied with **each** crane.
- **Heavy Duty Swivel Hook** fitted with **Safety Latch.**



If the model you require is not on this leaflet please contact us at the CAM Work. We can produce one off unit's to a customers specific requirements.

There are many other products in our range not covered by this leaflet. Workshop Presses, Wheel Removal Trolleys, Transmission Jacks, Axle Stands, Trolley Cranes, Tyre Changers and Cleaning Cabinets

The appearance or specification of equipment described or illustrated in this leaflet may differ as improvements or amendments are incorporated in line with our policy of continuous improvement.

To ensure efficient operation of this equipment it must be maintained in accordance with the manufacturer's requirements by authorised service personnel.

FOLDING CRANE SPECIFICATIONS

Model No.	½ tonne C.R.L.500	¾ tonne C.R.L.750	1 tonne C.R.L.1000
Capacity Position 1	508 Kg	750 Kg	1000 Kg
Capacity Position 2	381 Kg	600 Kg	750 Kg
Capacity Position 3	254 Kg	500 Kg	500 Kg
Min. Height Hook to ground (1)	220	220	232
Max. Height Hook to Ground (2)	2270	2270	2282
Column Height (3)	1520	1520	1530
Overall Base Length (4)	1690	1690	1690
Max. Width Between Legs (5)	800	800	800
Max. Overall Width (6)	930	930	930
Height to Top of Legs	130	130	142
Diameter of Wheels	100 mm	100 mm	125 mm
Weight	95 Kg	100 Kg	130 Kg
LEG STRADDLE ARRANGEMENT			

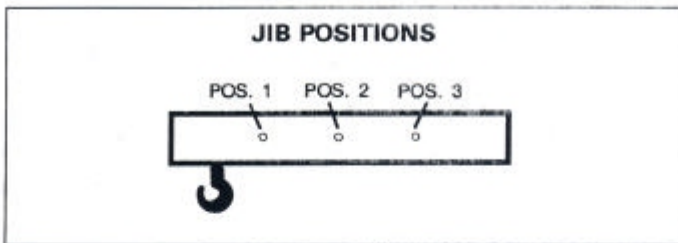
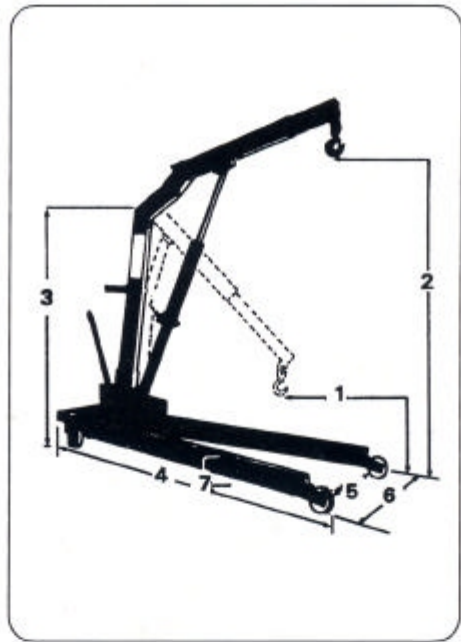

CAUTION

NEVER ALLOW RAM TO REACH FULL STROKE THIS COULD DAMAGE SEAL OR HYDRAULIC CYLINDER.

FAULT FINDING

Handle Raises Under Load	Handle Lowers Under Load	Will Not Lift Load	Will Not Lift Full Height	Will Not Hold Load	Pump Feels Spongy Under Load	FAULT FINDING
		X	X		X	The Hydraulic unit could be low on oil. See Maintenance.
		X	X		X	The hydraulic unit could be airbound. See Maintenance.
X	X	X		X		Valves might not be closing. Make certain release valve is closed starting with jib in lowered position slowly raise the jib a few feet. Open the valve and let jib descend into lowered position. Valve should now operate properly.